

WITH MORE THAN 60 YEARS OF EXPERIENCE IN COMPRESSOR TECHNOLOGY AND HIGHLY DEDICATED EMPLOYEES, OUR FOCUS IS ON DEVELOPING AND

APPLYING ADVANCED COMPRESSOR TECHNOLOGIES TO ACHIEVE STANDARD SETTING PERFORMANCE FOR LEADING PRODUCTS AND BUSINESSES AROUND THE WORLD.

SECCOP

THE NEW XV COMPRESSOR SMALL IS THE NEW BIG



Up to 40%
efficiency gain

Low height of
100 mm

Low noise of
32 dB(A)

Low weight of
4.8 kg

Up to 20 l extra
storage volume
in cooling
cabinets

Broad dynamic
range (1:4)
and adaptable
capacity

Reduces costs
and sensitivity
towards raw
material

Eases process
handling and
stock

NEVER HAS ANYTHING SO

small

PERFORMED SO **GREAT**



The new XV variable capacity compressor is the result of years of in-house research and development at Secop. It really is the result of our unique ambition to set a new future standard for household compressors.

Intelligently combining an extremely small size with extremes in high performance, the Secop XV compressor pioneers the global demands for innovation, efficiency and sustainability.

The XV compressor represents a new beginning and rethinking of matters. Instead of being an improvement of our existing compressor platforms the small Secop XV compressor is based on a completely new system approach and new technology.

Up to 40% efficiency gain

Low height of 100 mm

Low noise of 32 dB(A)

Low weight of 4.8 kg

Up to 20 l extra storage volume in cooling cabinets

Broad dynamic range (1:4) and adaptable capacity

Reduces costs and sensitivity towards raw material

Eases process handling and stock

THE EVOLUTION OF REVOLUTION



The XV compressor is the result of a small team of in-house engineers dedicated to challenge the status quo.

Their aim, was to create a compressor that would break the 100 mm height mark for the first time and was as light as possible. They also wanted this small and light compressor to be more efficient than large fixed speed compressors.

As if that was not enough. The compressor should be both more profitable and more sustainable.

In order to do so, the team acknowledged that they had to forget everything they had learned and start all over again. Knowing that what they create will start a cool revolution.

The team developed a new technological platform called System Effective Coefficient Of Performance (SECOP) and combined with the external rotor motor technique, they had the basis for the XV compressor. Tests quickly showed that the impossible was not that impossible at all.

One of the leading household brands, BSH Group (BSH Bosch und Siemens Hausgeräte GmbH) has joined the development of the intelligent XV compressor closely.

With this new series, BSH is looking forward to setting new standards itself and also have much greater flexibility in production, due to its adaptable capacity for various applications.

In that respect, the XV is already on the way to become a vital part of a new generation of innovative home appliance solutions at BSH Group and other leading household brands.

Up to 40% efficiency gain

Low height of 100 mm

Low noise of 32 dB(A)

Low weight of 4.8 kg

Up to 20 l extra storage volume in cooling cabinets

Broad dynamic range (1:4) and adaptable capacity

Reduces costs and sensitivity towards raw material

Eases process handling and stock

SECOP XV COMPRESSOR A NEW STANDARD FOR COOL SAVINGS



Danish Technological Institute has together with EUDP and the producer Vestfrost Solutions made comprehensive energy tests of commercial wine coolers. Results show that the variable speed Secop XV5.0KX compressor ensures a 47% overall energy savings compared to wine coolers with fixed speed compressors.

Design and usability are important matters in the light commercial market, but above all rates costefficiency. The refrigerators, freezers and coolers are always in use. This is why improved energy efficiency along with increasing environmental standards is so essential to the business.

Together with Danish Technological Institute and EUDP – a program that furthers new energy-friendly technologies – the Danish producer Vestfrost Solutions made numerous tests, both in laboratories and 'real life' in order to ensure that their new wine coolers also would set a new standard for energy savings.

WINE COOLER + XV COMPRESSOR WITH VARIABLE SPEED = UP TO OVERALL 47% ENERGY SAVINGS

The criteria included a compressor, that could combine high performance and low energy consumption with temperature precision and low noise. Tests demonstrated that the Secop XV5.0KX compressor was a very good match.

In contrast to fixed compressors the XV5.0KX is able to adjust the supplied cooling capacity of the compressor to the needed cooling capacity of the cabinet by operating at different speeds.

This rules out the constant stop-and-go motion and leads to a more balanced cooling temperature and reduces energy consumption considerably. Results showed the Secop XV5.0KX compressor managed the same high performance as the fixed compressors but used 36% less energy.

BEST IN CLASS + BEST IN FIT

The XV compressor made the Vestfrost Solutions wine cooler take a best-in-class leap from energy efficiency class B to energy efficiency class A+ and provided simultaneously improvements on noise levels – an instrumental feature when choosing wine coolers.

Furthermore, the compressor was able to demonstrate great flexibility. Due to its extremely small size and weight, it only took minor adjustments to make the Secop compressor fit in with the preexisting cabinet.

With the XV5.0KX, it is possible to reduce energy consumption without big changes to appliance design.

A NEW COOL FOR WINE COOLERS

Vestfrost Solutions has been pleased with the outcome and so has the different end users who already have had the chance to try out the "upgraded" wine coolers.

They mention the new cooling qualities as something to look out for and naturally the prospect of saving both energy and total costs.

Up to 40% efficiency gain

Low height of 100 mm

Low noise of 32 dB(A)

Low weight of 4.8 kg

Up to 20 l extra storage volume in cooling cabinets

Broad dynamic range (1:4) and adaptable capacity

Reduces costs and sensitivity towards raw material

Eases process handling and stock

TECHNICAL DATA



Secop's revolutionary X-Series compressor range is entirely new and relies on new compressor technology that Secop has developed in-house.

The completely new platform not only offers the highest system efficiency, but is also with its dimensions challenging the standards for compressor size in the future.

The innovative design from a production point of view is a pioneer which has all-welded parts that are assembled by the latest robotic automated systems, ensuring a trendsetting quality level.

Research and development is a high priority at Secop and we continue to deliver innovative, energy saving products to OEMs and end users alike.

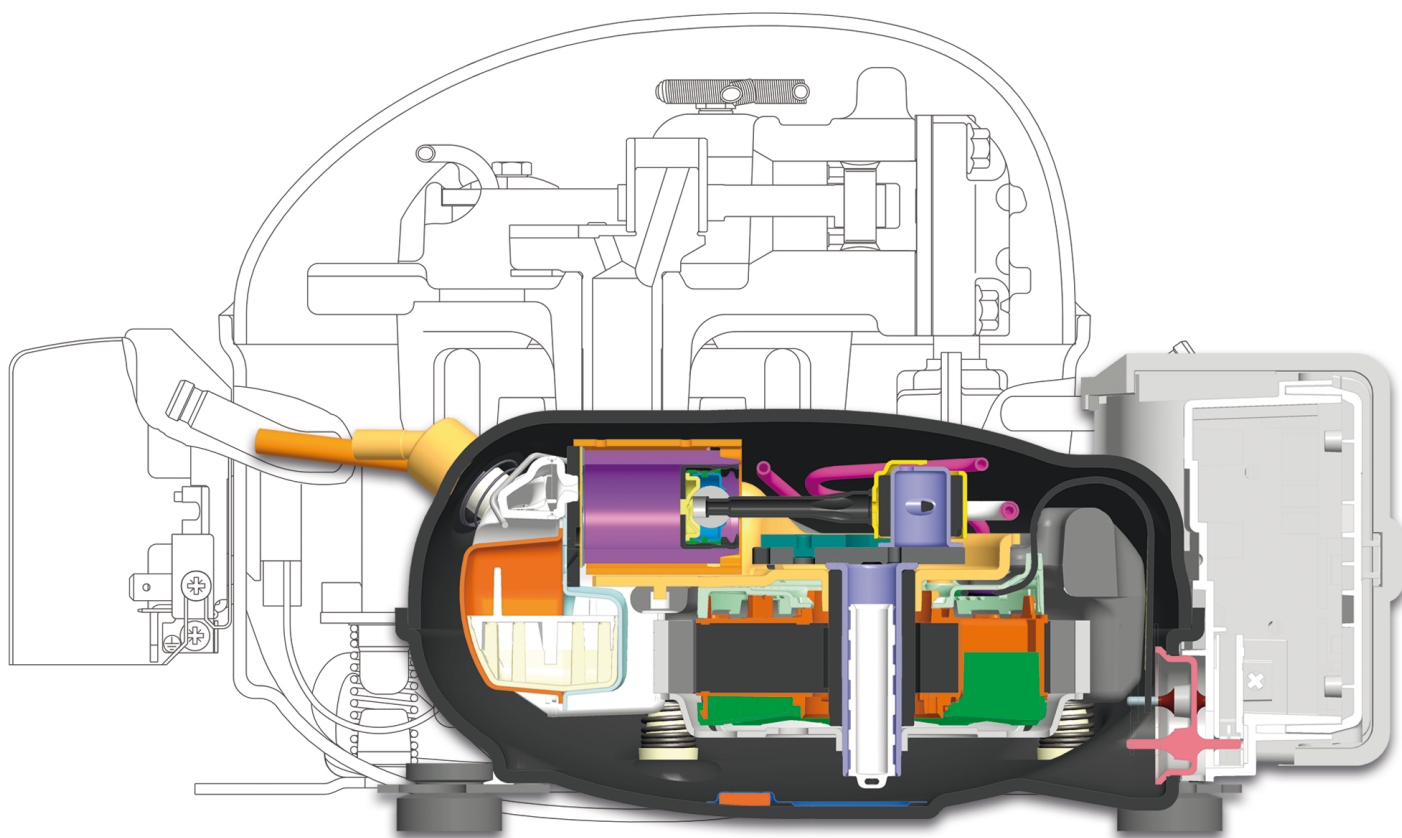

The XV compressor compared to an NL compressor

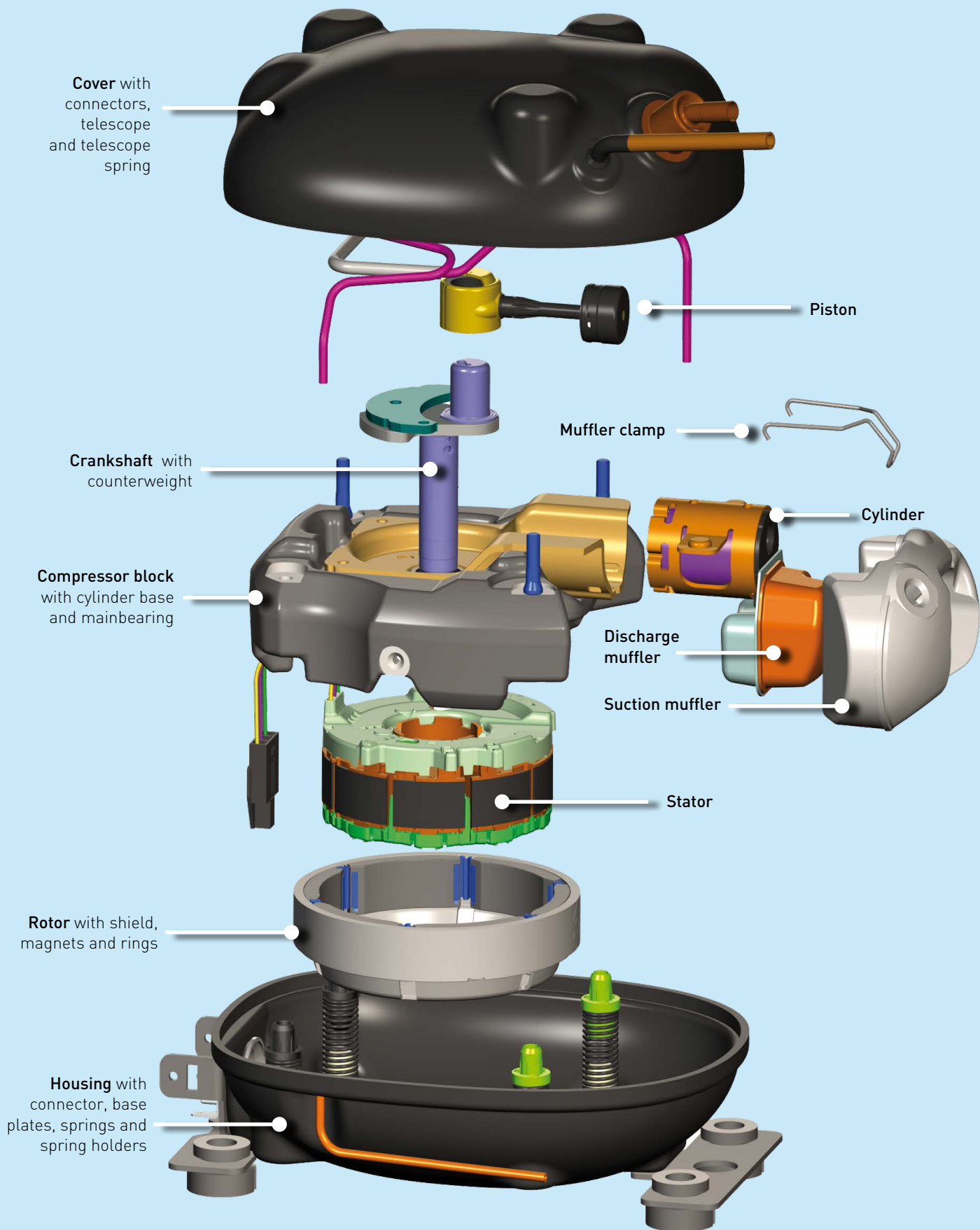

XV features

- eXtremely small
- eXtremely light
- eXtremely efficient
- eXtremely flexible

... your benefits

- Additional storage volume for refrigerators
- Less weight, easier handling, lower transport costs
- Increased system efficiency
- Adaptable capacity for various applications

XV-KX COMPRESSORS, 220-240 V, 50/60 Hz

General (code numbers)	XV5.0KX	XV7.2KX	XV8.0KX
Compressor, without electronic unit (4.8 kg)	108H5013	108H7211	108H7712
Electronic unit (attached) - XV-AEO/Freq.* Inputs: Thermostat, frequency signal, Modbus	105N5022	105N5022	105N5022
Electronic unit (detached) - XV-Frequency Input: Frequency signal	105N5052	105N5052	105N5052
Electronic unit (attached, PFC) - XV-AEO/Freq. Inputs: Thermostat, frequency signal, Modbus	105N5320	105N5320	105N5320
Approvals	Electronic unit with PFC = Power Factor Correction according to EN 61000-3-2:2014 EN 60335-2-34 with Annex AA (VDE), GB 4706.17 (CCC/CQC)		

* AEO algorithm: In AEO (Adaptive Energy Optimizing) speed mode the XV compressor will always adapt its speed to the actual cooling demand. The AEO function is very suitable for tropical applications, systems with huge load variations and applications where energy is an important issue. Furthermore it can be an advantage to use it when it is difficult to determine at what speed the compressor should run.

Application		LBP/MBP	LBP	LBP
Application				
Evaporating temperature	°C	-35 to 5	-35 to 0 [-5/-10]	-35 to 0 [-5/-10]
Voltage range / frequency	V/Hz	160 - 264 / 50/60	160 - 264 / 50/60	160 - 264 / 50/60
Speed range	rpm		1000 - 4000	

Remarks: HST capable (high starting torque, start against differential pressure).
All measured performance data include losses caused by electronic unit.

Performance data ASHRAE LBP (220 V, 50/60 Hz • static cooling) @ -23.3 °C evaporating temperature													
Speed	rpm	1000	1200	1600	4000	1000	1200	1600	4000	1000	1200	1600	4000
Cooling capacity	W	22.0	27.2	37.5	92.9	39.1	47.1	63.0	145	43.6	54.1	75.1	165
Power consumption	W	13.2	15.9	21.5	56.1	21.7	26.1	34.8	85.9	24.0	29.3	39.9	96.0
COP	W/W	1.67	1.71	1.75	1.66	1.80	1.81	1.81	1.69	1.82	1.85	1.88	1.72

Performance data Optimization Point (220 V, 50/60 Hz • static cooling • pc = 35 °C / Tliq = 35 °C / Tsuc = 32 °C) @ -25 °C evap. temp.													
Speed	rpm	1000	1200	1600	4000	1000	1200	1600	4000	1000	1200	1600	4000
Cooling capacity	W	27.8	34.1	46.0	106	42.1	50.5	67.4	150	44.7	54.8	75.1	164
Power consumption	W	12.9	16.0	21.7	55.5	19.0	22.9	30.9	76.9	20.0	24.6	33.8	85.6
COP	W/W	2.15	2.14	2.12	1.90	2.22	2.20	2.18	1.95	2.23	2.23	2.22	1.92

Dimensions			
Height	mm	A	97
		B	91
Suction connector	location/I.D. mm angle material seal	C	6.2 12° Copper Rubber plug
		D	6.0 7° Copper Rubber plug
Discharge connector	location/O.D. mm angle material seal	E	3.2 30° Cu-plated steel Rubber plug
		Connector tolerance	I.D. mm 6.2 ±0.09. 6.0 ±0.1. 3.2 ±0.05

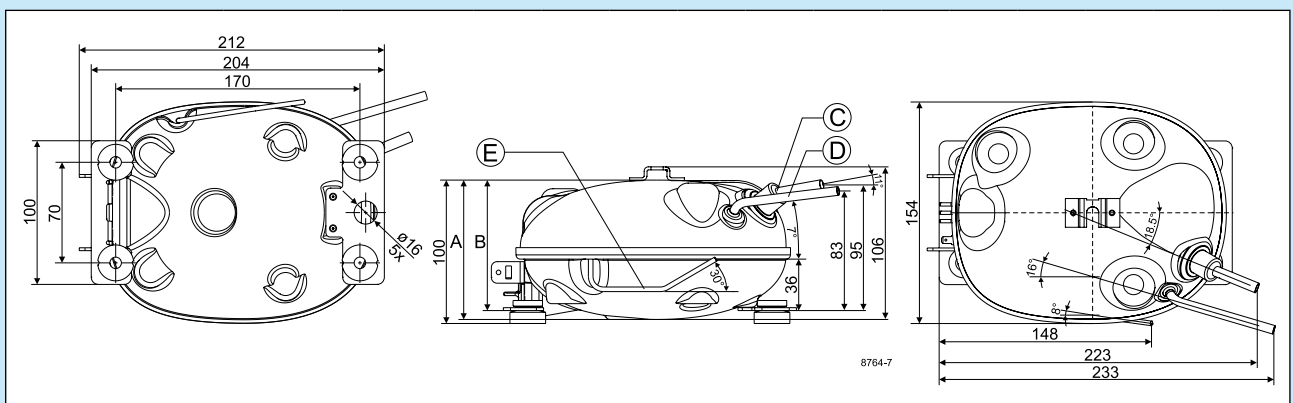

Electronic unit XV-AEO/Freq. 105N5022 (160-264 V, 50/60 Hz) - attached

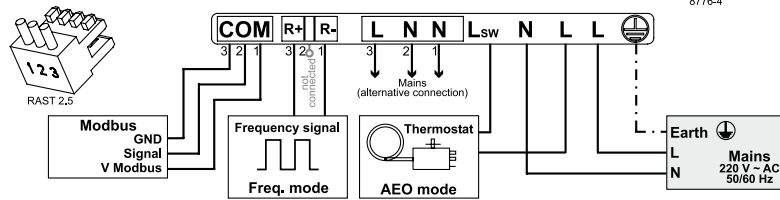
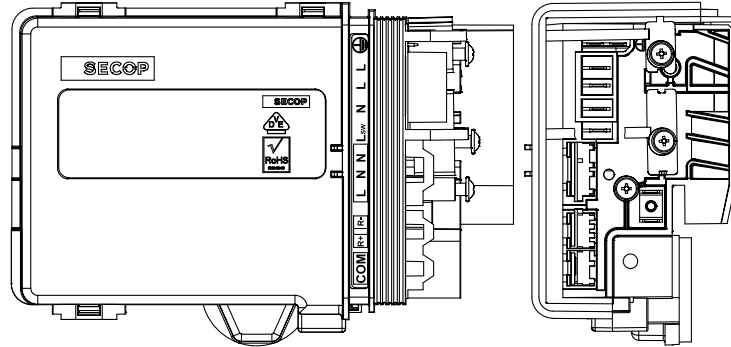

8776-4

Electronic unit XV-Frequency 105N5052 (160-264 V, 50/60 Hz & 105N5150 (100-127 V, 50/60 Hz) - detached

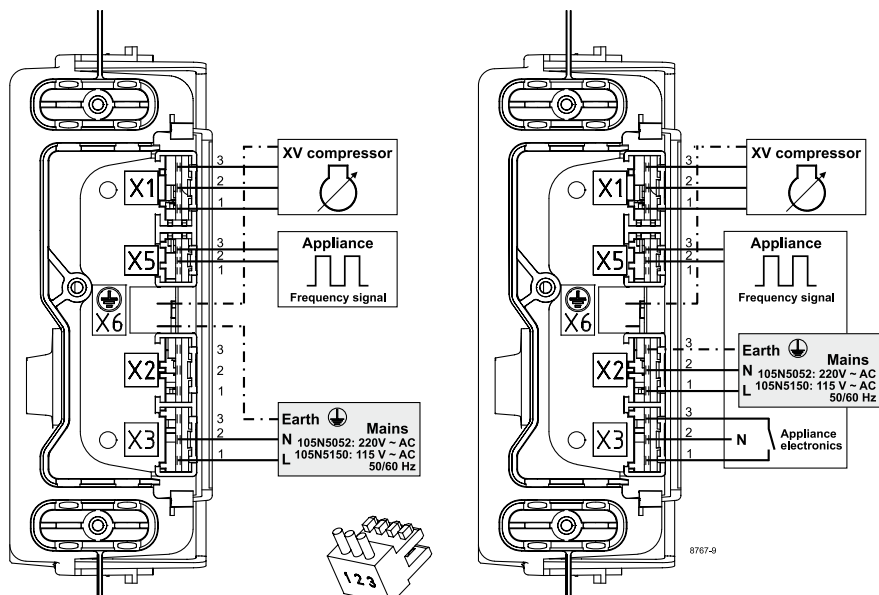

Option A: Standard

RAST 2.5

Option B: Appliance electronics connected

8767-0

Electronic unit **XV-AEO/Freq.** 105N5022 with PFC (160-264 V, 50/60 Hz) - attached

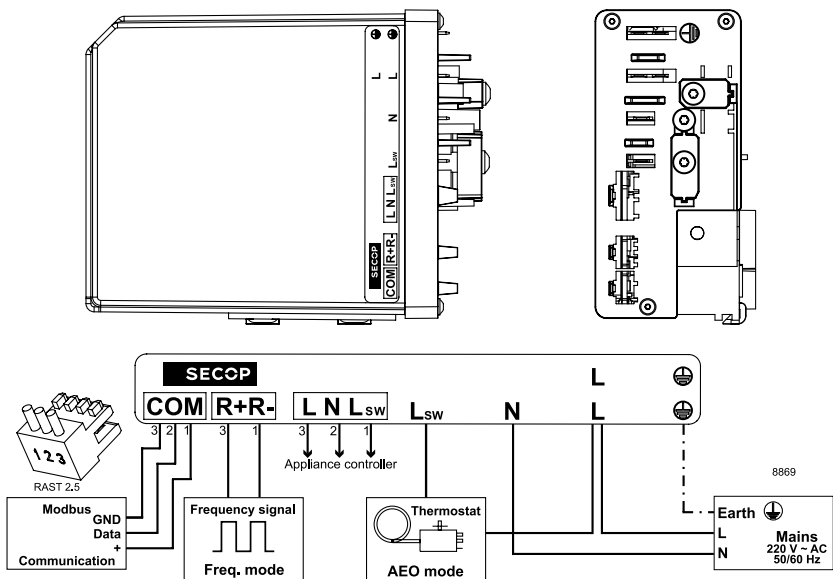

Electronic unit **XV-AEO/Freq.** 105N5312 (100-127 V, 50/60 Hz) - attached

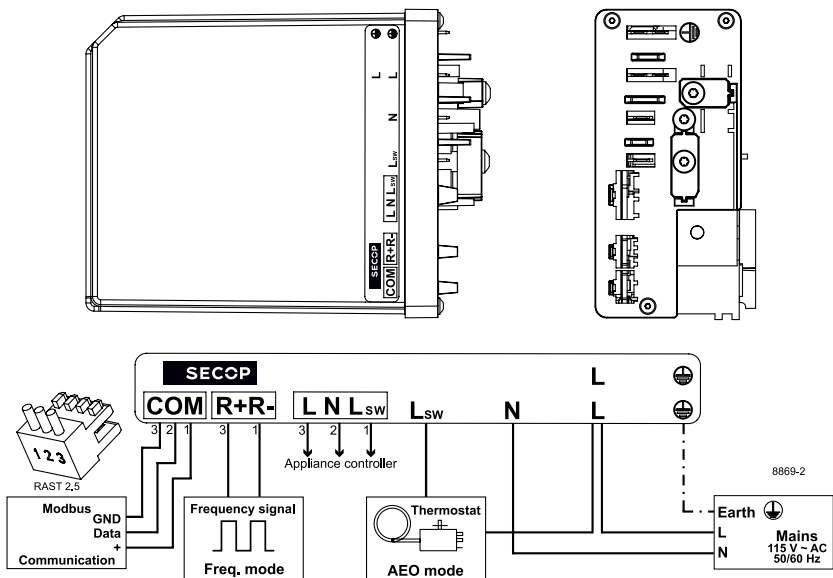

Electronic unit **XV-AEO/Freq.** 105N5310 (100-127 V, 50/60 Hz) - attached, under development

